

DOUGHPRO[®]

STEARNS PRODUCT DEVELOPMENT CORPORATION

Operations Manual

DP1300

Automatic Dough Press

Requires Self Contained Air Compressor

Doughpro

20281 Harvill Ave
Perris, CA 92570

Phone (951) 657-0379

Toll Free (800) 624-6717

Fax (951) 657-4594

Website: www.doughpro.com

E-Mail: info@doughpro.com

Listed:



Intertek 4001284 Intertek 4001284

Congratulations!

Your selection of the Doughpro DP1300 is a sound business decision. Doughpro equipment is a result of the highest quality engineering and time-tested design. Your machine, combined with Doughpro's reputation of innovation in dough press equipment manufacturing, insures the continuing capability of delivering the best-decorated product possible.

This manual describes installation, operation, and maintenance procedures for your new model DP1300.

Your model DP1300 machine will have a long trouble-free life. Read this manual carefully and keep it with your machine; it's your key to proper operation and lasting service.

Installation



DOMESTIC

Use a separate 15 amp AC circuit. Only industrial extension cords with proper wire size should be used; size 16/3 wire for distance up to 25 feet, and size 14/3 for distance up to 50 feet.



INTERNATIONAL

Use a designated 16 amp AC circuit. Only industrial extension cords with proper wire size (2.5 sq. mm) shall be used.

Make sure there is a proper electrical wall outlet located within reach of the cord and plug attached to the press. Then place the press in an area which allows for "swing clearance" of the lower platen plus vertical and horizontal clearance of the press itself.

Limited Machine Warranty

Doughpro warrants this dough press machine, when operated under normal

conditions, to be free from manufacturing defects in material and workmanship for a period of one year on parts and labor from the invoice date.

This warranty will be effective only when Doughpro authorizes the original purchaser to return the product to the factory in Perris, California freight prepaid and only when the product, upon examination, has proven to be defective.

This warranty does not apply to any machine that has been subjected to misuse, negligence or accident.

Doughpro shall not be liable for the injury, loss or damage, direct or consequential, arising out of the use or the inability to use the product.

No claim of any kind shall be greater in amount than the sale price of the product or part to which claim is made.

This is the sole warranty given by the company, it is in lieu of any other warranties, expressed or implied, in law or in fact, including the warranties of merchantability and fitness for a particular use, and is accepted such by the purchaser in taking delivery of this product.

Specifications

Electrical:

120V/50-60Hz/1450W/12.5Amps/AC

Also available; specify when ordering:

240V/50-60Hz/1450W/6.5Amps

Includes 72" cord and NEMA approved plug.

Shipping Weight:

200lbs. (91kg.) – DP1300

280 lbs. (127 kgs.) – DP1400C

Safety Summary

WARNING

In case of power cord damage, do not attempt to repair or replace the power cord. Contact the manufacturer or the local distributor.





WARNING

Avoid touching hot surfaces while operating the machine.



CAUTION

During normal operation, the base of the machine must be installed or placed above the wall socket.



CAUTION

When servicing or cleaning the machine, make sure that the power cord is removed from the wall socket.

Operation Timer/Temperature Control

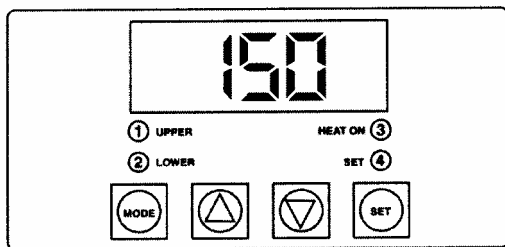

Fig. A

Solid State Controller

This controller has three (3) control features:

1. Temperature – May be set from 100°-425°F (38°-163°C)
2. Time – Time may be set from 1 second to 10 minutes.
3. Counter – Cycle counter counts the number of applications from 1 to 9999 (see additional Notes – Counter).
4. “ⓄLower” (Fig. A) Refers to models using upper and lower heated surfaces.

Controller Operation

1. Viewing the Modes of Operation:

- To view the set points of temperature, timer and counter, press MODE button to view the desired mode of operation.

2. Changing Temperature:

- Press **MODE** button until temperature is displayed.
- Press and hold **SET** button while pressing the **UP** (↑) and **DOWN** (↓) arrow buttons to desired temperature setting.

3. Changing Time:

- Press **MODE** button until time is displayed.
- Press and hold **SET** button while pressing the **UP** (↑) and **DOWN** (↓) arrow buttons to desired timer setting.



The **DISENGAGE** switch may be pressed anytime during a cycle, and the cycle will stop immediately, and the timer will reset.

4. Resetting the Counter

- Press MODE button until the counter is displayed.
- To Reset the Counter (# of Cycles), simultaneously push UP (↑) or DOWN (↓) arrow buttons (approx. 5 seconds).

PRESSING DOUGH:

For best results, your dough should be proofed before pressing, but it will also press directly out of your refrigerator.

Flour is not required to press a crust and should not be dusted on any part of the machine.

D1400C Cabinet & Compressor

1. After connecting the air hose line from the compressor to the press, plug it into the properly rated electrical outlet for your press and air compressor cabinet. Verify the electrical requirements against the nameplate on the

back of the press and air compressor cabinet.

Note: The compressor portion of the machine has a separate on/off switch located on the rear of the lower cabinet.

2. Switch the DP1300 to the ON position.

Note: Initial temperature setting of 150°F has been shown to be acceptable for most dough formulations; however, you may have to determine the best temperature for your own dough by trial and error testing of your product at different temperature settings.

3. Set the timer in accordance with the following information:

2-4 seconds –For warm dough with moderate yeast content.

2-6 seconds – For room temperature dough with moderate yeast content.

6-8 seconds – For cold dough right out of the refrigerator with low yeast content.

Remember that the timer does not actuate until the upper platen mates with the lower platen and resistance is felt.

4. Set the thickness control lever to “thick” or “thin” or anywhere in between these settings as your product requires.

Note: Diameter and thickness is determined through experimenting with your own dough and is a product of dough weight, temperature, pressing time, and thickness setting.

5. Swing open the lower platen and apply a quick spray of a good *water based* food release on the

lower platen. Doughpro offers its own food release spray NATURALLY CLEAR Model No. DPPC1. (See our catalog and price list for information.)

*Note: This spray **will not** affect the taste of your crust in any way.*

6. Place your pre-portioned ball of dough in the approximate center of the lower platen. Add another dash of spray to the top of the dough ball.
7. Close the platen and, with both hands, press the two green buttons on each side of the machine simultaneously.
8. Hold the buttons in until resistance is felt then release at once. The timer will actuate and, when the time cycle is completed, the upper platen will rise automatically (timer is preset at factory for six (6) seconds, but this is easily changed by following the upcoming instructions.)
9. Remove the crust, place on a disc, screen, pan or peel, add toppings and bake.

ADDITIONAL NOTES:

Serial Tags

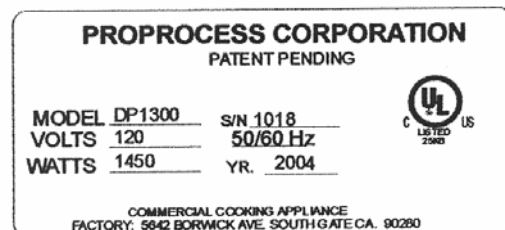

International Symbols



Power Off



Power On



Hot Surface



Protective Earth Terminal



Caution - Warning

Contact our factory or approved service agency (800) 624-6717 (U.S. only).

*Note: When contacting factory for information, parts or service instructions, it is of the **utmost importance** that the serial number of the machine be provided. This number can be found on the serial plate located on the rear of the machine.*

Preventative Maintenance Suggestions

The Doughpro DP1300 machines are relatively maintenance free. For a long and trouble-free life, the following preventative maintenance should be followed:

Daily Care:

1. ***Platens:*** Turn your machine off and allow to cool down before attempting to clean. These platens should *only* be cleaned with mild soap and warm water then wiped off with a clean, soft cloth or soft sponge. **Never use steel wool or harsh abrasives or you will cause costly damage.**
2. ***All other exterior surfaces:*** Here again a daily wipe down with mild soap and warm water will do the job quite nicely. **Never use steel wool or harsh abrasives or you will cause costly damage.**

Service Problems:

DP1300 AUTOMATIC PIZZA PRESS

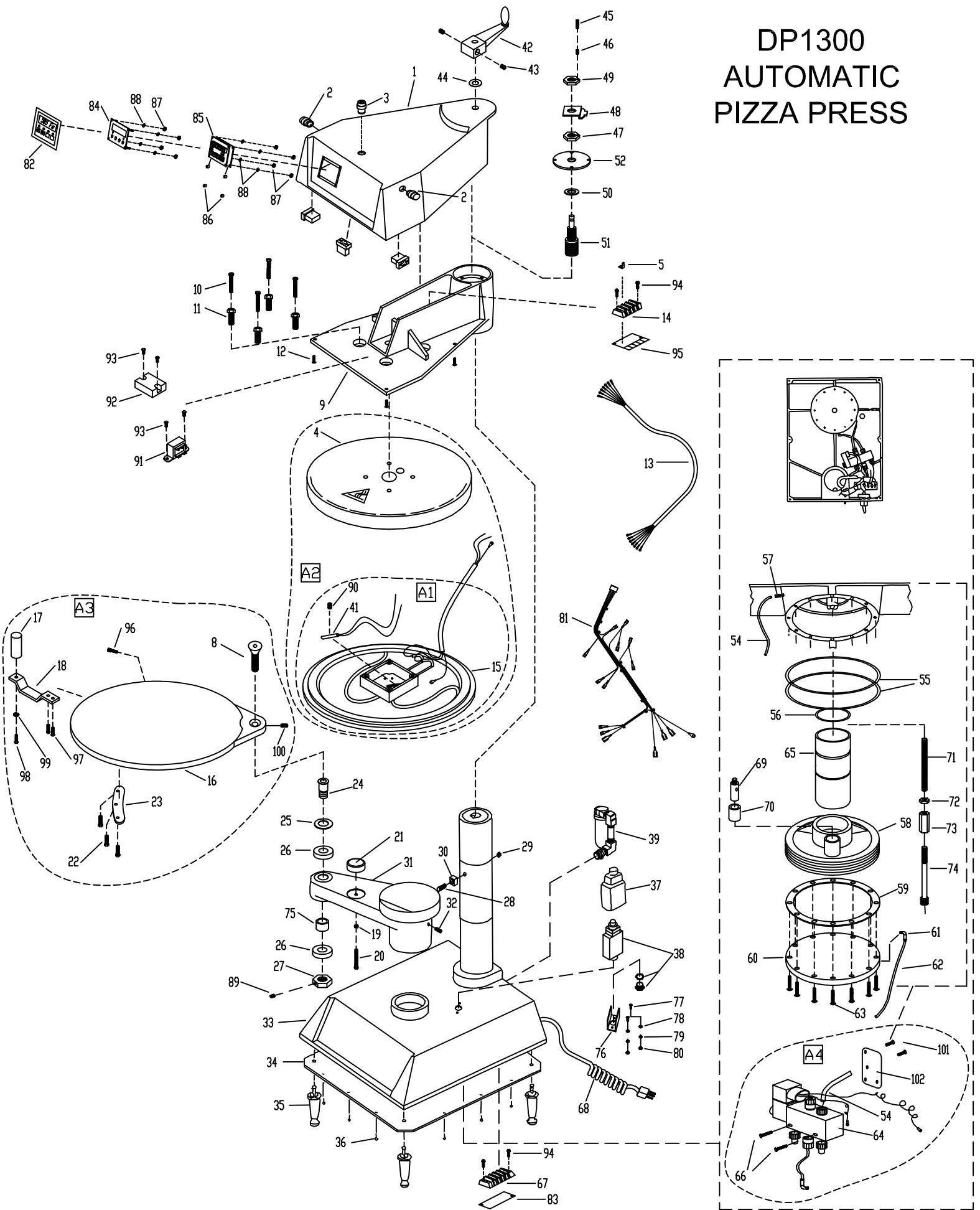

DOUGHPRO PROPROCESS CORPORATION
PARTS LIST FOR DP1300 PIZZA PRESS

REF. #	DESCRIPTION	DP1300A 120 ~ AC	DP1300B 240 ~ AC
1	HOUSING, INSTRUMENT	110102522	110102522
2	START BUTTON ASSEMBLY	11051845	11051845
3	STOP BUTTON ASSEMBLY	11051850	11051850
4	SHROUD, UPPER PLATEN	1109336	1109336
5	¼" 90° Q.D. TERMINAL	KT45	KT45
8	SCREW, FLAT HEAD SOCKET	SF12202	SF12202
9	ARM	11021	11021
10	BOLT, HEX LOCKING	BH51618212G5	BH51618212G5
11	BOLT, LEVEL	11067	11067
12	SCREW, HOUSING	SB142034	SB142034
13	CABLE, POWER DISTRIBUTION	1101025068	1101025068
14	TERMINAL BLOCK 6 STAGE	6016	6016
15	UPPER PLATEN	110074120	110074240
16	LOWER PLATEN	11032	11032
17	KNOB, PRESSURE APPLY	MPSK215	MPSK215
18	HANDLE, BRACKET	11063	11063
19	NUT, HEX (PIVOT ARM)	NH1420	NH1420
20	BOLT (PIVOT ARM)	BH1420114	BH1420114
21	BUMPER (LOWER PLATEN)	110503450	110503450
22	SCREW (GUIDE, LOW PLATEN)	BH516181S	BH516181S
23	GUIDE, LOWER PLATEN	11044	11044
24	STUD, THREADED (LOWER PLATEN)	110249065	110249065
25	BUSHING, PLASTIC (LOWER PLATEN)	110249049	110249049
26	BEARINGS, SEALED	62042NSL	62042NSL
27	NUT, JAM (PIVOT ARM) MACHINED	110102570	110102570
28	SCREW (POST)	SSH38161	SSH38161
29	NUT, LOCKING (POST)	NHSL3816	NHSL3816
30	ANTI-ROTATION BLOCK	110148	110148
31	PIVOT ARM	11030	11030
32	SCREW, SET (PIVOT ARM)	SST38161	SST38161
33	BASE ASSEMBLY	11011	11011
34	COVER PLATE, BASE	11054	11054
35	LEG, PLASTIC (4X)	106006333446	106006333446
36	SCREW, COVER PLATE (BASE)	SP83238	SP83238
37	BOOT, PLUNGER SWITCH	11062	11062
38	SWITCH, ALIGNMENT (BASE)	110102	110102
39	FILTER (BASE)	11064184	11064184
41	SENSOR, TEMPERATURE CONTROLLER	110949110	110949110
42	CRANK, ADJUSTMENT (THICK/THIN)	11061A	11061A
43	SCREW, SET KNURLED CUP POINT	SST5161838KN	SST5161838KN
44	WASHER (ADJUSTMENT CRANK)	11064	11064
45	SCREW, SET LOCKING (THICK/THIN ADJ.)	SST38161	SST38161
46	SCREW, SET (THICK/THIN ADJ.)	SST142038	SST142038
47	JAM NUT LOWER (THICK/THIN ADJ.)	NHJ114	NHJ114
48	STOP CONTROL (THICK/THIN ADJ.)	11061	11061
49	JAM NUT UPPER (THICK/THIN ADJ.)	11070	11070
50	THRUST WASHER (THICK/THIN ADJ.)	11059	11059
51	SCREW, ADJUSTMENT	11042	11042
52	THRUST PLATE (THICK/THIN ADJ.)	11058	11058
54	AIR, TUBE, POLY AIR 3/8 O.D. X 7" LONG	T38	T38
55	O-RING (PISTON)	MPSR138	MPSR138
56	O-RING (PISTON ROD)	62308	62308

**DOUGHPRO PROPROCESS CORPORATION
PARTS LIST FOR DP1300 PIZZA PRESS**

57	FITTING, AIR	AQ68P6X4	AQ68P6X4
58	PISTON ASSEMBLY	11039	11039
59	GASKET (PISTON)	MPSG140	MPSG140
60	PISTON COVER	11013	11013
61	FITTING, AIR	AQ69P4X2	AQ69P4X2
62	AIR TUBE	TPE4014	TPE4014
63	SCREW, SOCKET HEAD (PISTON COVER)	SSH14201	SSH14201
64	SOLENOID VALVE 12V ASSY	110559003	110559003
65	PISTON ROD	11074	11074
66	SCREW	SP832112S	SP832112S
67	TERMINAL BLOCK (BASE)	6016	6016
68	POWER CORD	110174	110175
69	GUIDE POST (PISTON)	11072	11072
70	BUSHING (GUIDE POST)	MPSB070	MPSB070
71	THREADED (GUIDE STUD)	11048	11048
72	NUT, HEX (GUIDE STUD)	NHL3816	NHL3816
73	COUPLING NUT (SAFETY SWITCH)	NC3816134	NC3816134
74	SCREW, SOCKET (GUIDE STUD)	SSH38164	SSH38164
75	BEARING SPACER (LOWER PLATEN)	11046	11046
76	MICRO SWITCH BRACKET	11096118	11096118
77	SCREW, MICRO SWITCH BRACKET	SP83258S	SP83258S
78	LOCK SPLIT WASH, MICRO SWITCH BRACKET	WSL8	WSL8
79	WASHER, MICRO SWITCH BRACKET	WSAE8	WSAE8
80	HEX NUT, MICRO SWITCH BRACKET	NH832	NH832
81	WIRE HARNESS	110559050	110559050
82	CONTROL PANEL OVERLAY	OPROPP1818	OPROPP1818
83	MARKER STRIP #6	MS6016	MS6016
84	CONTROL FACIA	11086027	11086027
85	DIGITAL CONTROL	1101025052	1101025052
86	SPACER, NYLON	110969111	110969111
87	NUT, DIGITAL CONTROL	NH632	NH632
88	WASHER, INTERNAL TOOTH LOCK	WLIT6	WLIT6
89	SET SCREW, NUT, JAM (PIVOT ARM)	SST1032316	SST1032316
90	SET SCREW, SENSOR	SST381612	SST381612
91	TRANSFORMER	11096975	11096975
92	RELAY	MPR90217	MPR90217
93	SCREW	SP83214	SP83214
94	SCREW	SP83212	SP83212
95	MARKER STRIP #6	MS6016	MS6016
96	SCREW, LOWER PLATEN	SSH14201	SSH14201
97	SCREW, BRACKET HANDLE	BH14201S	BH14201S
98	SCREW	SB38161	SB38161
99	SPLIT LOCK WASHER	WLS38	WLS38
100	SET SCREW, CONE POINT	SST142038CP	SST142038CP
101	SCREW	SP103238S	SP103238S
102	MOUNTING PLATE AIR VALVE	110559028	110559028
A1	UPPER PLATEN WIRING ONLY	110102531200	110102531201
A2	UPPER PLATEN COMPLETE ASSEMBLY	110102531100	110102531101
A3	LOWER PLATEN ASSEMBLY	11032A	11032A
A4	SOLENOID VALVE ASSY KIT	110559030	110559030

WWW.DOUGHPRO.COM

DP1300_021711_2496.DOC

DP1300 WIRING DIAGRAM DIGITAL CONTROLLER

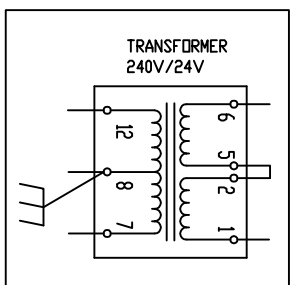
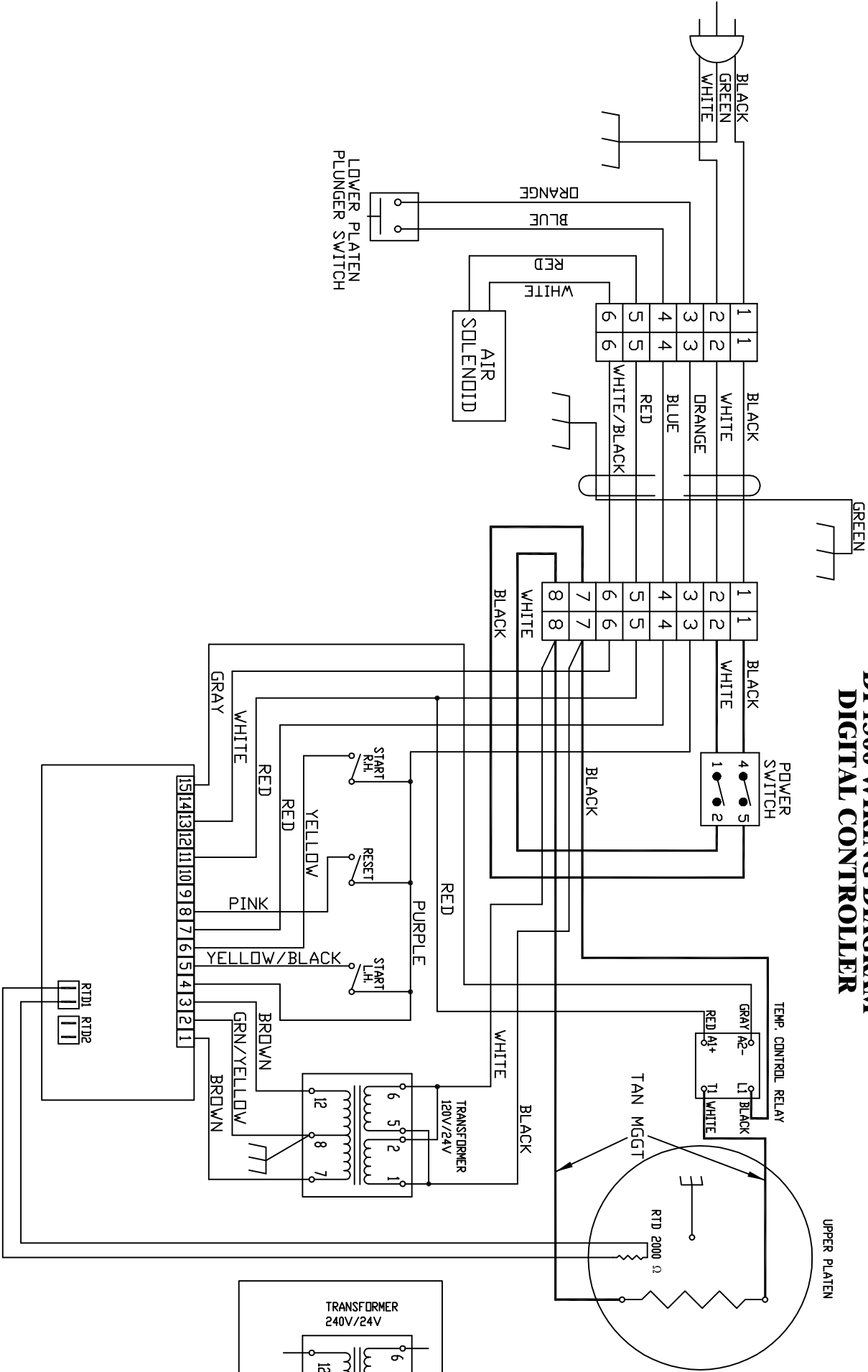

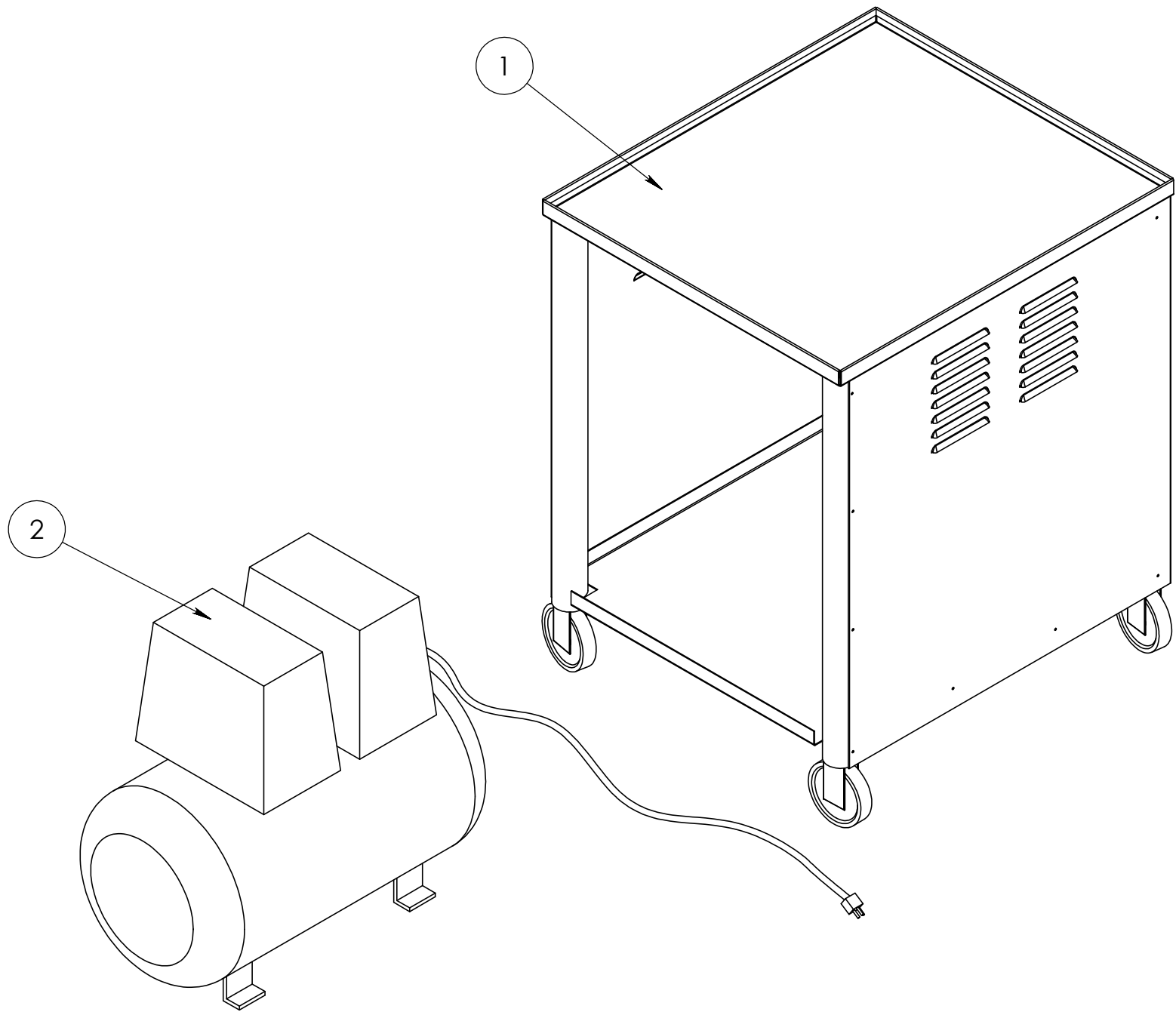

DOUGHPRO
PARTS LIST FOR DP1500 COMPRESSOR CABINET

REF. #	DESCRIPTION	PART #
1	CABINET ASSEMBLY	110119700
2	COMPRESSOR	110109210



Stearns Product Development Corp. 20281 Harvill Ave. Perris, Ca 92570
(951) 657-0379 Fax (951) 657-4954

Warranty & Return Policy

STEARNS PRODUCT DEVELOPMENT CORPORATION warrants all products manufactured by it against defects in workmanship or materials from the date of purchase for a period of (1) year on parts and labor. **This warranty applies to only equipment purchased and used in the United States.**

Exclusions:

- 1. WOOD / GAS FIRED OVENS: STEARNS PRODUCT DEVELOPMENT CORPORATION** warranty applies to the main body of the oven being steel / refractory and insulation shall be free from defects in materials and workmanship for a period of four (10) years from the date of purchase. The gas equipment shall be free from defects in materials and workmanship for a period of one (1) year from the date of purchase. This warranty excludes the tandoori and home oven. Lifetime warranty against cracks on oven floor.
- 2. TANDOORI & HOME OVENS: STEARNS PRODUCT DEVELOPMENT CORPORATION** warrants the Tandoori & Home Oven including gas equipment shall be free from defects in materials and workmanship for a period of one (1) year from the date of purchase.
- 3. Air compressors are excluded from this warranty,** but **STEARNS PRODUCT DEVELOPMENT CORPORATION** may act as a warrantor in certain instances regarding these compressors. The air compressor manufacturer provides a limited warranty and a copy of this warranty is furnished with all compressors sold by **STEARNS PRODUCT DEVELOPMENT CORPORATION**. For prompt handling of compressor warranty claims the instructions of the compressor manufacturer must be adhered to.
- 4. Equipment built to special order as well as accessories** are not returnable unless defective within the terms of this warranty.
- 5. In no event shall STEARNS PRODUCT DEVELOPMENT CORPORATION be liable for consequential damages arising out of the failure of any of its products if operated improperly or caused by normal wear or damage by operator abuse.**

Returned Merchandise Policy:

Should it become necessary to return any of the company's products, the following instructions must be adhered to: First, contact our customer service department for approval and a return authorization number. *Please have the serial number of your item available at that time.* All merchandise must be shipped *freight prepaid* by customer or service agency. Subject to the inspection of the product by the company, a restocking charge of 20% of the Net purchased price paid to **STEARNS PRODUCT DEVELOPMENT CORPORATION** will be assessed. Merchandise may not be returned for credit without *prior written approval* of **STEARNS PRODUCT DEVELOPMENT CORPORATION**. Collect shipments *will not* be accepted. No returns after 60 days of original shipment date on machines. Purchased parts may not be returned after 30 days. If upon inspection by **STEARNS PRODUCT DEVELOPMENT CORPORATION** or its authorized agent it is determined the equipment has not been used in an appropriate manner, has been modified, or has not been properly maintained, or has been subject to misuse, misapplication, neglect, abuse, accident, unauthorized modification, damage during transit, delivery, fire, flood, act or war, riot or act of God, then this warranty shall be deemed null and void.

Terms & Conditions:

- Prices indicated in the PRICE LIST are suggested retail prices and are shown in U.S. DOLLARS.
- Terms of Payment: 1% 10 days, NET 30 days.
- NEW ACCOUNTS:** Satisfactory credit information must be provided before open account status can be extended. Unless agreed otherwise, all shipments will be made C.O.D., CASH IN ADVANCE.
- PRICING:** Prices, specifications, model numbers, capacities and accessories are subject to change without notice.
- FREIGHT / ROUTING:** Method of shipment will be determined by **STEARNS PRODUCT DEVELOPMENT CORPORATION** unless otherwise advised by PURCHASER.
- DAMAGED CLAIMS:** All merchandise shipped at purchaser's risk. Inspection must be made by purchaser at time goods are received. If goods are damaged, the PURCHASER shall request that the agent of the transportation company make a written notation on the proper shipping documents immediately and then file a claim for damage. **GOODS DAMAGED IN SHIPMENT ARE NOT RETURNABLE.**
- RETURNS:** Machines may not be returned after 60 days. Purchased parts may not be returned after 30 days. A restocking fee of 20% will be assessed on non-warranty returns.
- TAXES:** Prices indicated herein DO NOT include State, Federal, Local or foreign taxes or duties, nor do they include fees, permits, insurance or other levies, all of which are the responsibility of the purchaser.
- All orders are subject to acceptance by **STEARNS PRODUCT DEVELOPMENT CORPORATION**.
- Possession of this price list shall not be considered an offer to sell.