

DOUGHPRO[®]

STEARNS PRODUCT DEVELOPMENT CORPORATION

Operations Manual

DP2000

Dual Heat Dough Press

Doughpro

20281 Harvill Ave
Perris, CA 92570

Phone (951) 657-0379

Toll Free (800) 624-6717

Fax (951) 657-4594

Website: www.doughpro.com

E-Mail: info@doughpro.com

Listed:



Congratulations!

Your selection of the Doughpro DP2000 is a sound business decision. Whether your intended use is to press or par bake dough for pizzas, tortillas, mushi skins or other appropriate dough products, rest assured that you have made a wise choice.

Doughpro equipment is a result of the highest quality engineering and time-tested design. Your machine, combined with Doughpro's reputation of innovation in dough press equipment manufacturing, insures the continuing capability of delivering the best-decorated product possible.

This manual describes installation, operation, and maintenance procedures for your new model DP2000.

Your model DP2000 machine will have a long trouble-free life. Read this manual carefully and keep it with your machine; it's your key to proper operation and lasting service.

Included with your shipment:

- 5 Rubber Feet
- Platen Saver **If your unit has polished platens**

Installation

DOMESTIC

Use a separate 15 amp AC circuit. Only industrial extension cords with proper wire size should be used; size 16/3 wire for distance up to 25 feet, and size 14/3 for distance up to 50 feet.



INTERNATIONAL

Use a designated 16 amp AC circuit. Only industrial extension cords with proper wire size (2.5 sq. mm) shall be used.



Make sure there is a proper electrical wall outlet located within reach of the cord and plug attached to the press. Then place the press in an area that allows for "swing clearance". Note that the upper platen rotates up to 90°, in a backward rotation, to facilitate removal of the dough product after the press cycle has been completed. Also note that the machine requires a vertical, clear space of 33" from the bottom of the machine to the top of the pull handle.

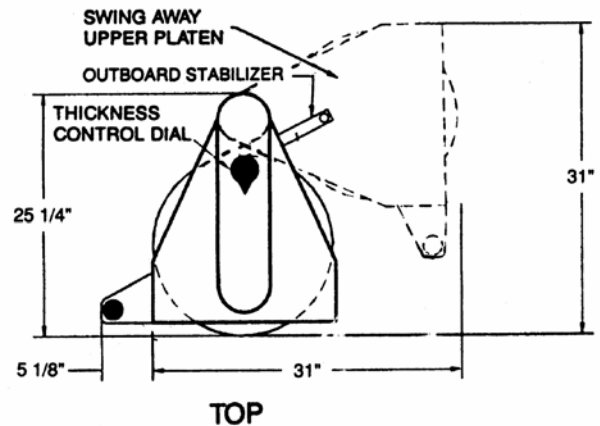

Limited Machine Warranty

Doughpro warrants this dough press machine, when operated under normal conditions, to be free from manufacturing defects in material and workmanship for a period of one year on parts and labor from the invoice date.

This warranty will be effective only when Doughpro authorizes the original purchaser to return the product to the Factory in Perris, California

prepaid and only when the product, upon examination, has proven to be defective.

This warranty does not apply to any machine that has been subjected to misuse, negligence or accident.

Doughpro shall not be liable for the injury, loss or damage, direct or consequential, arising out of the use or the inability to use the product.

No claim of any kind shall be greater in amount than the sale price of the product or part to which claim is made.

This is the sole warranty given by the company, it is in lieu of any other warranties, expressed or implied, in law or in fact, including the warranties of merchantability and fitness for a particular use, and is accepted such by the purchaser in taking delivery of this product.

Specifications

Electrical:

240V/50-60Hz/2800W/11.66Amps

Requires 30 AMP outlet

Includes 72" NEMA 6-15P approved cord and plug.

Shipping Weight:

180lbs. (82kg)

Familiarize yourself with controls and operating mechanisms before attempting to use the DP2000. These are as follows:

- (A) Pull Pressing Handle for raising and lowering the upper platen. This action forces the mating of the platens.
- (B) Thickness Control Dial.
- (C) On/Off Button. The green light above the button will illuminate when turned on to indicate power is in the press.
- (D) Control Panel (*see Control Board Operations*)
- (E) Handle for swing-out platen.
- (F) Upper platen
- (G) Lower platen
- (H) Handle adjustments (*see Tightening the Pull-Down Handle*)

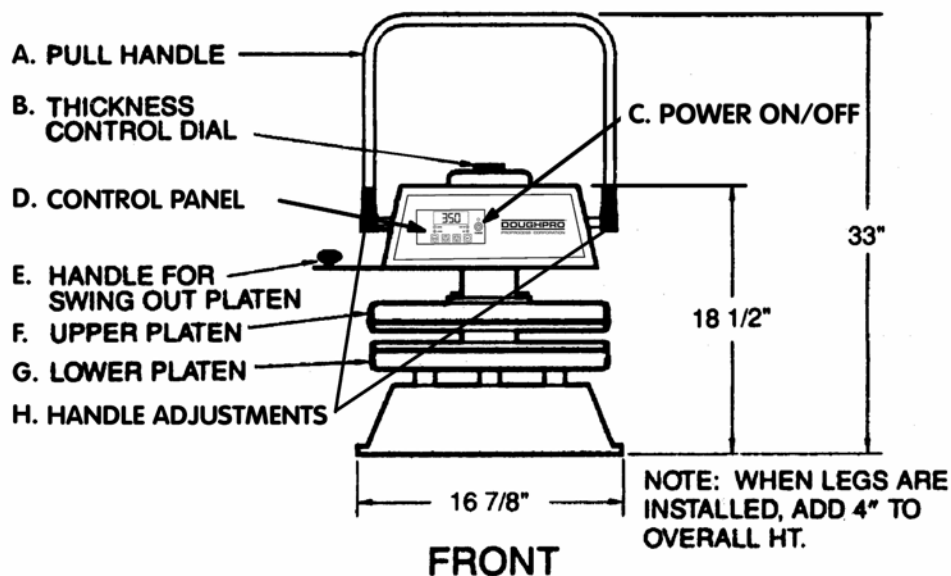



WARNING

In case of power cord damage, do not attempt to repair or replace the power cord. Contact the manufacturer or the local distributor.



WARNING

Avoid touching hot surfaces while operating the machine.



CAUTION

During normal operation, the base of the machine must be installed or placed above the wall socket.



CAUTION

When servicing or cleaning the machine, make sure that the power cord is removed from the wall socket.

Control Board Operations

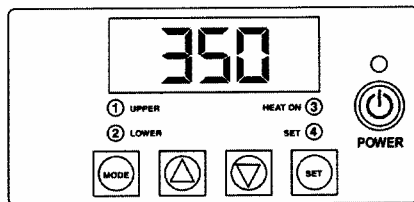

Solid State Controller

This controller has three (3) control features:

1. Temperature – Temperature may be set from 225°-450°F (107°-232°C). The factory default setting is 200°. If you would like to change this setting, simply follow the *Controller Operation* directions.

2. Counter – Cycle counter counts the number of applications from 1 to 9999 (*see additional Notes – Counter*).
3. Timer – A timer mode is available upon special request. If you would like to have the timer function installed, please call 1-800-624-6717

Controller Operation

Temperature Control

1. Press the **MODE** button until temperature is displayed.
2. Push and hold **SET** button and simultaneously push UP (▲) or DOWN (▼) arrow buttons to the desired temperature setting.

For the DP2000, both the upper and lower platens may be set to different temperatures.

- *Upper Platen:* Simply push the **MODE** button until the “upper” light is illuminated. Adjust the temperature as noted above.
- *Lower platen:* Simply push the **MODE** button until the “lower” light is illuminated. Adjust the temperature as noted above.

Dough Pressing Operations

SETTING CRUST THICKNESS CONTROL:

*The thickness is determined by dough weight and temperature setting on each platen. Setting crust thickness is as simple as the twist of a dial. The thickness adjustment dial can be located on the top of the DP2000. By means of trial and error, rotate the dial until desired thickness is obtained. **If your platens are polished they have been coated with *Platen Saver*. This product will prevent dough from sticking and make cleanup much easier. A sample bottle has been included along with an order sheet for your convenience. **Note: Never force the dial past its stop position or damage could occur.**

Dough Product	Press Only		Press & Par Bake	
	Temp	Press Time	Temp	Press Time
Pizza	150°F both platens	3 seconds	325°F both platens	7-15 seconds
Flour Tortilla	N/A		350°F both platens	1 quick second
Corn Tortilla	No heat, must use wax paper	3 seconds	N/A	
Mushi Skin	150°F both platens	3 seconds	N/A	

****To achieve consistent size flour tortillas of smaller than 10" you will need to only press 2 at a time as shown in the pictures included with the manual.***

PRESSING DOUGH:

1. First make sure you have the correct type electrical current or serious damage could occur!
2. Press the Power Button in order to turn the machine on. A green light will illuminate above the power button indicating that power is in the machine.
3. Both the upper and lower platens will heat up once you have adjusted your digital control to your desired setting. *Note: Different products require different temperature settings. In order to determine the right temperature setting for your product, refer to the following table simply as a guide for starting.*

Note: Keep in mind that dough formulations may differ, and that you may have to do some trial and error testing of different temperatures and platen pressure to arrive at the proper end result for your particular product.

Also note that the finished, after-pressing diameter of the finished dough piece is determined by the weight of the dough and the amount of pressure applied to the platens.

For best results, your dough should be proofed at room temperature before pressing, but it will also press directly out of your refrigerator. **Flour is not required to press a crust and should not be dusted on any part of the machine.**

No. DPPC1. (See our catalog and price list for information.)

*Note: This spray **will not** affect the taste of your crust in any way.*

6. Place your pre-portioned ball of dough in the approximate center of the lower platen. Add another dash of spray to the top of the dough ball.
7. Close the platen and pull the “U” shaped handle down to commence the pressing operation.
8. Hold the handle down for as long as you have determined to be the appropriate amount of time for your particular product and then simply pull the handle back up when you have completed.
9. Inspect your dough. If it is too thick, rotate the thickness control dial, located on the top of the machine, to the line marked “THIN”. Reverse this procedure if your product presses too thin. Experiment with temperature, dough weight, time, and pressure until you arrive at the desired result.
10. Remove the finished product by rotating the upper platen out of the way until you have sufficient space to do so. Place the dough on a screen or in a pan. Since the shape of the dough may be altered slightly in the transfer process, some hand fitting may be required. Add toppings, if desired, and now you are ready to bake.

ADDITIONAL NOTES:

Temperature

Note

Fahrenheit/Centigrade (Celsius) Conversion

*The temperature controller can be programmed to display either °F or °C. To change: Press the **MODE** button until the temperature is displayed, then push and hold the **SET** button for 10 seconds.*



Counter

The controller has a built in cycle counter.

- Press MODE button until the counter is displayed.
- Counter display range is 0000 to 9999.
- To reset the cycle counter, display the counter reading, then push and hold both UP (▲) and DOWN (▼) arrow buttons for 3 seconds until the counter resets to zero (0000) on the display.

Tightening the Pull-Down Handle

The pull-down pressing handle requires adjustment periodically to prevent it from free falling. Whenever the handle seems too loose or is falling by itself, the problem can be corrected easily and quickly as follows:

1. Using a 3/16” hex shaped Allen wrench, insert in key slot located on the right **beneath** the upper shroud.
2. Tighten until the press action of the handle becomes firm but not too tight.

International Symbols



Power Off



Power On



Hot Surface



Risk of Electrical Shock



Protective Earth Terminal





Ground



Caution - Warning

Serial Tags

PROPROCESS CORPORATION		
PATENT # 6,332,768		
MODEL DP2000	S/N 40000	 
VOLTS 240 ~	50/60 Hz	
WATTS 1500	YR. 200	
COMMERCIAL COOKING APPLIANCE FACTORY: 5842 BORWICK AVE. SOUTH GATE CA. 90280		

PART # SPRODP2000C

PROPROCESS CORPORATION		
PATENT # 6,332,768		
MODEL DP2000	S/N 20000	
VOLTS 240 ~	50/60 Hz	
WATTS 1500	YR. 200	
COMMERCIAL COOKING APPLIANCE FACTORY: 5842 BORWICK AVE. SOUTH GATE CA. 90280		

PART # SPRODP2000B

PROPROCESS CORPORATION		
PATENT # 6,332,768		
MODEL DP2000	S/N 10000	
VOLTS 120 ~	50/60 Hz	
WATTS 1500	YR. 200	
COMMERCIAL COOKING APPLIANCE FACTORY: 5842 BORWICK AVE. SOUTH GATE CA. 90280		

PART # SPRODP2000A

Preventative Maintenance Suggestions

The Doughpro DP2000 machines are relatively maintenance free. For a long and trouble-free life, the following preventative maintenance should be followed:

Daily Care:

1. **Platens:** These platens should *only* be cleaned with mild soap and warm water then wiped off with a clean, soft cloth or soft sponge. **Never use steel wool or harsh abrasives or you will cause costly damage.**
2. **All other exterior surfaces:** Here again a daily wipe down with mild soap and warm water will do the job quite nicely. **Never use steel wool or harsh abrasives or you will cause costly damage.**

Piston Maintenance:

In order to ensure proper and trouble free operation of the press piston, it is important that the machine be lubricated once every three (3) months, under normal operation. High volume users may require more frequent lubrication.

The lubricant used must be USDA H-1 authorized for food machinery. This lubricant can be ordered through Doughpro/Proprocess Corporation as part number # 110-002. Please follow these simple instructions:

1. Locate the grease port on the machine. Machines with pull down arms have a single grease port located below the upper head on the right side of the vertical post. Machines with swing-away upper heads have two grease ports; one on the right side of the vertical post and one on the back of the vertical post. All other machines have a single port. (refer to illustration)
2. Place grease gun head against grease port and apply enough pressure to allow gun head to engage the grease port.
3. Squeeze handle of grease gun which forces the grease into the piston. **One squeeze is all it takes.**

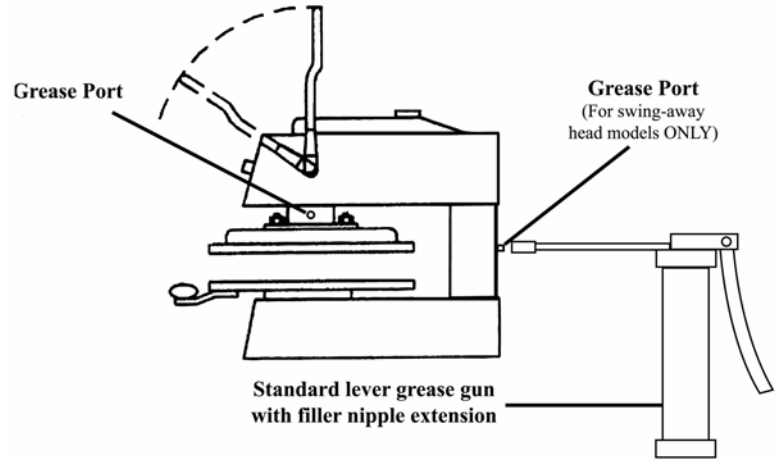

Service Problems:

Contact our factory or approved service agency (U.S. only). *Note: When contacting factory for information, parts or service instructions, it is of the **utmost importance** that the serial number of the machine be provided. This number can be found on the serial plate located on the rear of the machine.*

DP2000 EXPLOSION VIEW THE DOUGHPRO

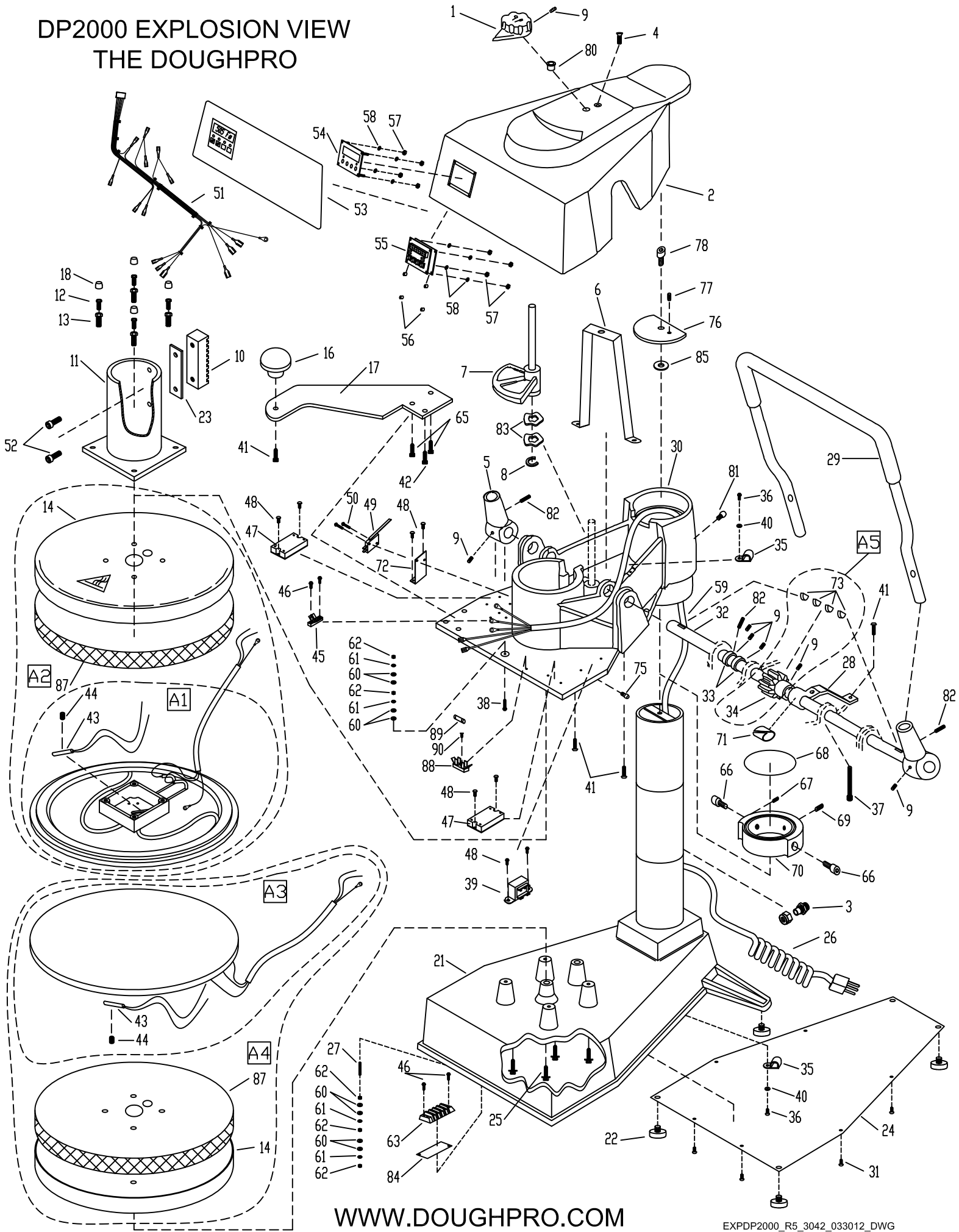

DOUGHPRO CORPORATION
PARTS LIST FOR DP2000

REF. #	DESCRIPTION	DP2000B 240 ~ AC
1	KNOB, THICK / THIN	1109309
2	HOUSING, INSTRUMENT	110118122
3	CABLE STRAIN RELIEF	3231
4	SCREW, HOUSING	SF142034
5	HANDLE SOCKET	11016650
6	BRACKET, HOUSING	110144130
7	CAM RAMP ASSEMBLY	1109310
8	RETAINING CLIP (CAM RAMP)	MPSC240
9	SET SCREW, GEAR BAR ASSEMBLY	SST142038
10	GEAR RACK	1109380
11	PISTON ASSEMBLY	11018974
12	LOCKING BOLT, ADJUSTMENT	BH51618134G5
13	BOLT, LEVEL ADJUSTMENT	1109367
14	SHROUD, UPPER PLATEN	1109336
16	KNOB (SWING)	110017
17	HANDLE SWING	110288210
18	CAP, VINYL (ADJUSTMENT SCREWS)	SC0687
21	BASE ASSEMBLY WITH POST	11061911
22	FEET, RUBBER (5 EACH)	RF209
23	SHIM, GEAR RACK	110144120
24	COVER PLATE, BASE	11010954
25	SCREW, LOWER PLATEN	SSH51618214
26	POWER CORD	110969175
27	SET SCREW, BASE GROUND	SST8321
28	TENSION STRAP ASSEMBLY	11041663
29	HANDLE, PRESSURE	1109390
30	ARM	11098421
31	SCREW, BASE COVER PLATE	SP83214
32	GEAR BAR	1109361
33	COLLAR, GEAR BAR	11013183
34	PINION GEAR	1109360A
35	CLAMP, CABLE	CC12
36	SCREW, CLAMP, CABLE	SP83238
37	SCREW, TENSION STRAP ADJUSTMENT	SSH1420314
38	SCREW, GROUND	SP8321
39	TRANSFORMER	11096975
40	WASHER, CLAMP, CABLE	WSAE8
41	SCREW, HANDLE SWING	SB142034
42	SCREW, HANDLE SWING	SSH142012
43	SENSOR ASSEMBLY BLUE	110949110
44	SET SCREW, SENSOR	SST381638
45	TERMINAL BLOCK	11098414
46	SCREW, TERMINAL BLOCK	SP83212
47	SOLID STATE RELAY	MPR90217
48	SCREW, RELAY & TRANSFORMER	SP83214
49	MICRO SWITCH	110969044
50	SCREW, MICRO SWITCH	SR44034
51	WIRE HARNESS	110589050
52	SCREW, GEAR RACK	SSH381634
53	CONTROL PANEL OVERLAY	OPRODP1100
54	CONTROL FACIA	11086027
55	DIGITAL CONTROL	11096905220

DOUGHPRO CORPORATION
PARTS LIST FOR DP2000

56	SPACER, NYLON	110969111
57	NUT, DIGITAL CONTROL	NH632
58	WASHER LOCK INT, DIGITAL CONTROL	WLIT6
59	POWER DIST CABLE	110589067
60	WASHER, GROUND	WSAE8
61	WASHER LOCK INTERNAL, GROUND	WLIT8
62	NUT, GROUND	NH832
63	TERMINAL BLOCK #6	6016
65	SCREW, HANDLE SWING	SSH142058
66	SCREW, COLLAR	SSH516181D
67	SCREW, COLLAR	SST142034
68	ORING, COLLAR	MPSS062
69	SCREW, COLLAR	SST5161834
70	COLLAR	11041323
71	BUSHING, BRASS (TENSION STRAP)	11018966
72	MICROSWITCH BRACKET	1101021213
73	WOODRUFF KEY	KW931634
75	ZERK FITTING	B792
76	ARM RETAINING PLATE	11056858
77	PIN, ROLL	PR18516
78	SCREW, ARM RETAINING PLATE	SSH1213112
80	BUSHING, INSTRUMENT HOUSING	212NN01420000
81	ZERK, FITTING	B610
82	SET SCREW, HANDLE SOCKET	SST14201
83	WAVE WASHER	5806282
84	MARKER STRIP	MS6016
85	WASHER, ARM RETAINING PLATE	WSAE12
87	FIBERGLASS INSULATION	MPSP251
88	FUSE HOLDER 1 AMP	MPPF708
89	FUSE BUSS 1 AMP	MPPF701R
90	SCREW PHILLIPS PAN 2-56 x 1/4	SP25614
A1	UPPER PLATEN WIRE ONLY	11098431100
A2	UPPER PLATEN COMPLETE ASSEMBLY	11098431200
A3	LOWER PLATEN WIRE ONLY	11098432100
A4	LOWER PLATEN COMPLETE ASSEMBLY	11098432200
A5	PINION GEAR ASSEMBLY	1109360A

WWW.DOUGHPRO.COM

PLDP2000_R5_3042_033012_DOC

DP2000 DIGITAL WIRING SCHEMATIC

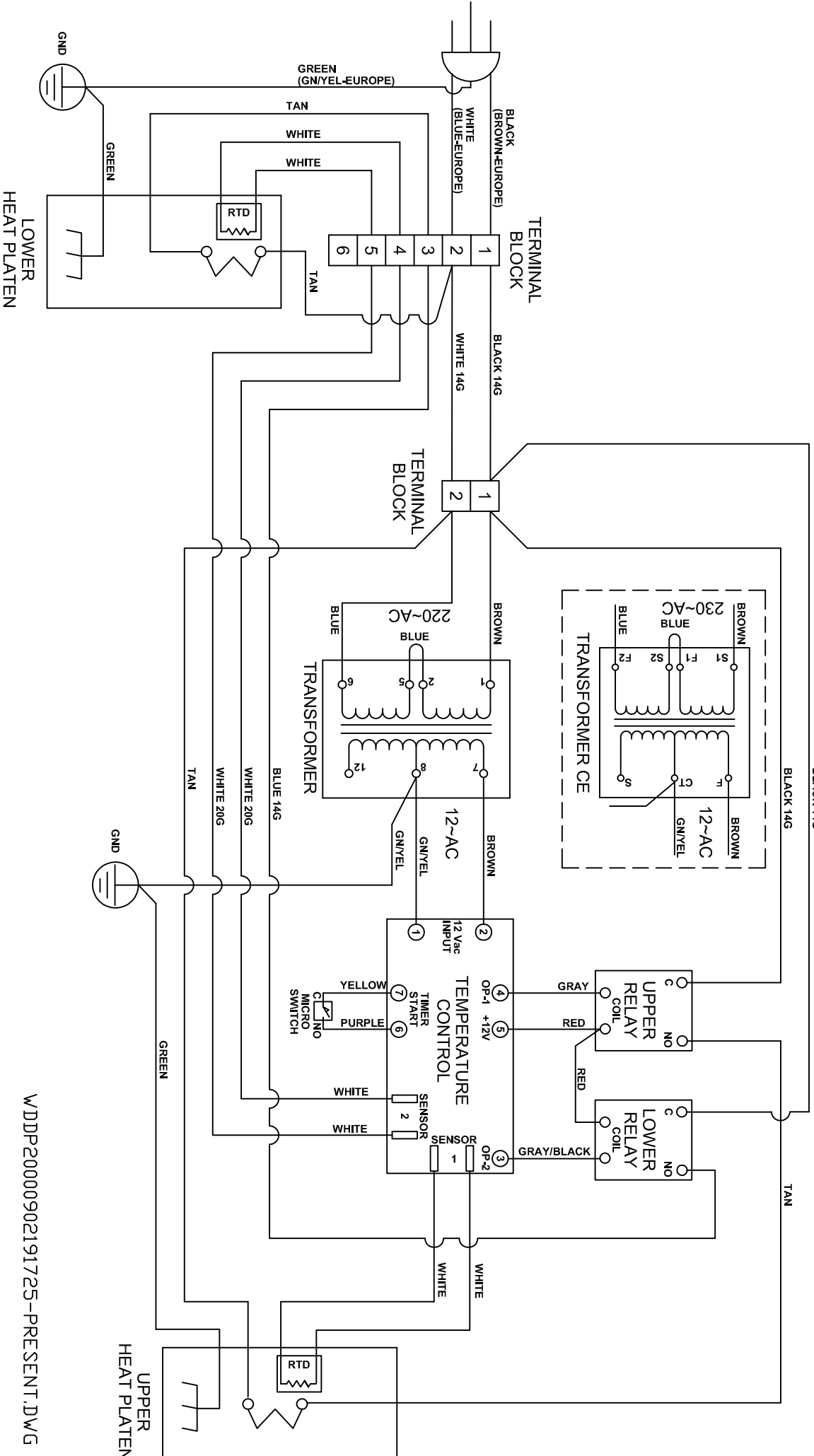



STEARNS PRODUCT DEVELOPMENT CORPORATION

Warranty & Return Policy

STEARNS PRODUCT DEVELOPMENT CORPORATION warrants all products manufactured by it against defects in workmanship or materials from the date of purchase for a period of (1) year on parts and labor. **This warranty applies to only equipment purchased and used in the United States.**

ALL WARRANTY SERVICE CALLS MUST BE APPROVED BY DOUGHPRO. IF THIS PROCEDURE IS NOT FOLLOWED, WARRANTY SERVICE WILL NOT BE COVERED.

Exclusions:

- 1. WOOD / GAS FIRED OVENS: STEARNS PRODUCT DEVELOPMENT CORPORATION** warranty applies to the main body of the oven being steel / refractory and insulation shall be free from defects in materials and workmanship for a period of four (10) years from the date of purchase. The gas equipment shall be free from defects in materials and workmanship for a period of one (1) year from the date of purchase. This warranty excludes the tandoori and home oven. Lifetime warranty against cracks on oven floor.
- 2. TANDOORI & HOME OVENS: STEARNS PRODUCT DEVELOPMENT CORPORATION** warrants the Tandoori & Home Oven including gas equipment shall be free from defects in materials and workmanship for a period of one (1) year from the date of purchase.
- 3. Air compressors are excluded from this warranty, but STEARNS PRODUCT DEVELOPMENT CORPORATION** may act as a warranty expeditor in certain instances regarding these compressors. The air compressor manufacturer provides a limited warranty and a copy of this warranty is furnished with all compressors sold by **STEARNS PRODUCT DEVELOPMENT CORPORATION**. For prompt handling of compressor warranty claims the instructions of the compressor manufacturer must be adhered to.
- 4. Equipment built to special order as well as accessories** are not returnable unless defective within the terms of this warranty.
- 5. In no event shall STEARNS PRODUCT DEVELOPMENT CORPORATION be liable for consequential damages arising out of the failure of any of its products if operated improperly or caused by normal wear or damage by operator abuse.**

Returned Merchandise Policy:

Should it become necessary to return any of the company's products, the following instructions must be adhered to: First, contact our customer service department for approval and a return authorization number. *Please have the serial number of your item available at that time.* All merchandise must be shipped *freight prepaid* by customer or service agency. Subject to the inspection of the product by the company, a restocking charge of 20% of the Net purchased price paid to **STEARNS PRODUCT DEVELOPMENT CORPORATION** will be assessed. Merchandise may not be returned for credit without *prior written approval* of **STEARNS PRODUCT DEVELOPMENT CORPORATION**. Collect shipments *will not* be accepted. No returns after 60 days of original shipment date on machines. Purchased parts may not be returned after 30 days. If upon inspection by **STEARNS PRODUCT DEVELOPMENT CORPORATION** or its authorized agent it is determined the equipment has not been used in an appropriate manner, has been modified, or has not been properly maintained, or has been subject to misuse, misapplication, neglect, abuse, accident, unauthorized modification, damage during transit, delivery, fire, flood, act or war, riot or act of God, then this warranty shall be deemed null and void.

Terms & Conditions:

- Prices indicated in the PRICE LIST are suggested retail prices and are shown in U.S. DOLLARS.
- Terms of Payment: 1% 10 days, NET 30 days.
- NEW ACCOUNTS:** Satisfactory credit information must be provided before open account status can be extended. Unless agreed otherwise, all shipments will be made C.O.D., CASH IN ADVANCE.
- PRICING:** Prices, specifications, model numbers, capacities and accessories are subject to change without notice.
- FREIGHT / ROUTING:** Method of shipment will be determined by **STEARNS PRODUCT DEVELOPMENT CORPORATION** unless otherwise advised by PURCHASER.
- DAMAGED CLAIMS:** All merchandise shipped at purchaser's risk. Inspection must be made by purchaser at time goods are received. If goods are damaged, the PURCHASER shall request that the agent of the transportation company make a written notation on the proper shipping documents immediately and then file a claim for damage. **GOODS DAMAGED IN SHIPMENT ARE NOT RETURNABLE.**
- RETURNS:** Machines may not be returned after 60 days. Purchased parts may not be returned after 30 days. A restocking fee of 20% will be assessed on non-warranty returns.
- TAXES:** Prices indicated herein DO NOT include State, Federal, Local or foreign taxes or duties, nor do they include fees, permits, insurance or other levies, all of which are the responsibility of the purchaser.
- All orders are subject to acceptance by **STEARNS PRODUCT DEVELOPMENT CORPORATION**.
- Possession of this price list shall not be considered an offer to sell.