

Mobile Tortilla Preparation Station

Press and grill tortillas, all in one station, without leaving your work area.

Here's a tortilla production/display counter when combined with our tortilla grills and dual heat presses results in a high volume mini-production plant.

It's so simple to operate; even your least skilled employees will be making world class tortillas after only a few minutes of simple instructions. **Here's how it works:**

Step 1: Dough balls are pre-portioned and stored in (8)18"x26" trays located beneath the **DPTPS**.

Step 2: Using our model **DP2000** tortilla press, simply lay down the dough ball(s) and press it flat.

Step 3: Place the flattened tortillas on either our model **TW2025** or **TW1520** grill. The tortillas will finish in a matter of minutes and then they can be served hot **FRESH** off the grill.



Shown with TW2025, DP2000 & Sheet Pans. (not included)

Store 8 full size 18" x 26" sheet pans. Large 2 bin storage space.

Can hold **ANY COMBINATION** of Tortilla or Pizza presses and grills.

Custom configurations can be built for your specific requirements.

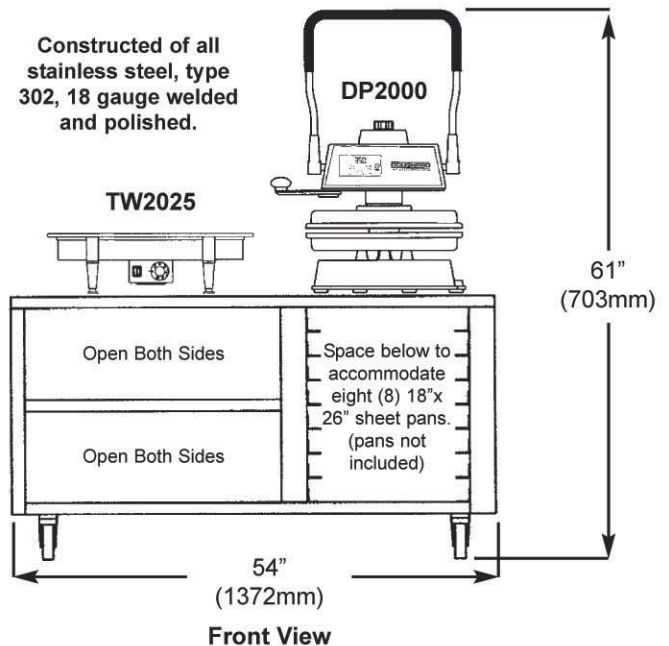
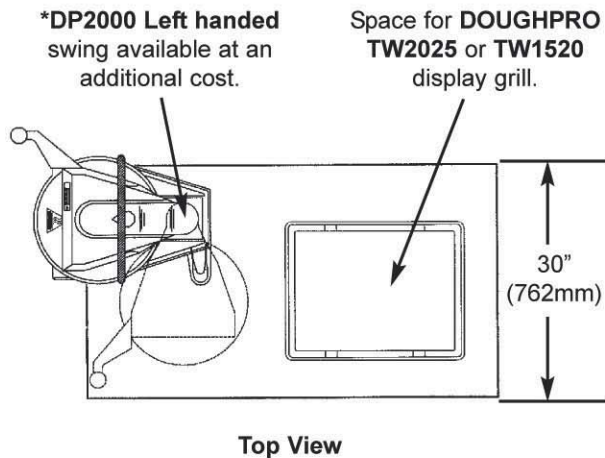

Specifications, Details and Prices are subject to change without prior notice. Please call for current pricing.

DOUGHPRO
20281 Harvill Ave, Perris, CA 92570
(951) 657-0379 (800) 624-6717 Fax (951) 657-4594



DOUGHPRO®

STEARNS PRODUCT DEVELOPMENT CORPORATION

Website: www.doughpro.com E-Mail: info@doughpro.com