

MODELS: DPO4-W, DPO4-GB, DPO4-FG

The Doughpro 4 ft. oven is manufactured from high grade castable ceramic material, enclosed completely in a housing of 1/4 " thick mild steel. This mild steel outer frame with built in lifting hooks makes installation easy and eliminates potential damage to the oven. The inside diameter of the oven is 36 inches and it has a 8 sq ft. cooking surface. The oven is listed with UL and has EPH/NSF4 classification. The gas system meets AGA/CSA requirements. The same oven may use wood, coal or gas fuel. The difference being the number of gas burners fitted. From a cooking perspective, the oven will operate superbly whether fired by coal, gas, wood or a combination of the two fuels.

The spectacular performance of the Doughpro Oven is a result of the huge thermal mass of the ovens unique ceramic convex domed ceiling. The oven is TWICE the weight of all other pre-cast ovens on the market.. The convex ceiling is 16" above the floor giving it the most powerful cooking potential and never seen before thermal efficiencies.

The cooking surface (hearth) of the oven uses high quality 3" thick alumina bricks, renowned for their excellent cooking attributes and incredible wear resistance. The use of bricks avoids the unsightly cracking associated with one piece floors. These bricks sit upon a 1"VF insulating board & a further 1/4" reinforced steel base.

The unique design of the ovens gives them the cooking advantages of a fully assembled unit whilst having incredible installation flexibility of a modular oven that can fit through a standard 32" doorway. The reduced installation costs can be significant. The oven body comes with an unmatched, exclusive 4 year guarantee.

The oven is approved for installation to within 1" of combustible material, check for local building and fire codes. The oven exhausts through a spigot above the mouth . The oven must be flued in accordance with local and/or national codes. The options include :-

- (1.). Use of a NFPA approved exhaust hood or
- (2.). Direct Connect Venting through a mechanically assisted grease rated chimney.

Allow 16" sq. ventilation into underside of oven for secondary gas burner air.

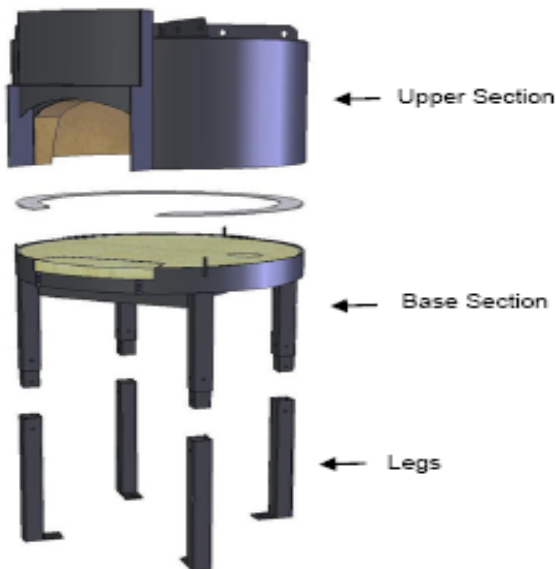

UNIQUE FEATURES:-

Custom features: Windows, Radiant Flames (thermostatically controlled) & spotlights
Stainless steel plug doors for all oven mouths.
Any gas type - Specify at order time.

OPTIONAL OVEN ACCESSORIES / SERVICES

- INSTALLATION
- GLASS DOOR
- DIGITAL THERMOMETER
- INTERNAL SPOT LIGHTS
- PIZZA TOOLS
- DOUGH PRESSES
- COMMISSIONING
- DESIGN ARTWORK
- VIEWING WINDOW
- GRANITE OR STAINLESS MANTLE
- MOUTH EXTENSIONS TO FACILITATE EASIER FACADE CONSTRUCTION

Services Required:
57,000 BTU. 3/4" GAS connection. Nat. & Propane versions available.
Connections to approved flue/ducting

APPROXIMATE PIZZA CAPACITY PER HOUR:- @700°F will cook

| Size | 16" | 12" | 10" | 8" |
|-----------------------|-----|-----|-----|----|
| Pizza Per Hour | 10 | 25 | 35 | 70 |

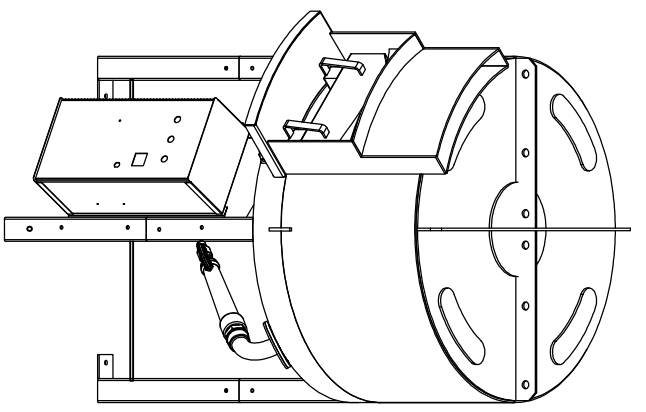
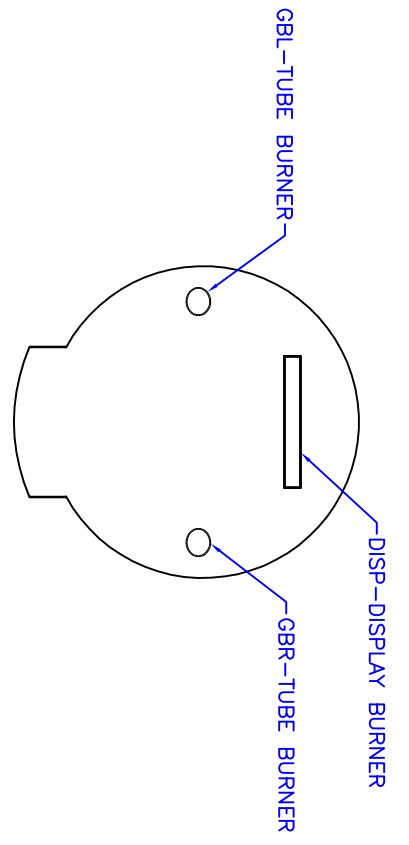
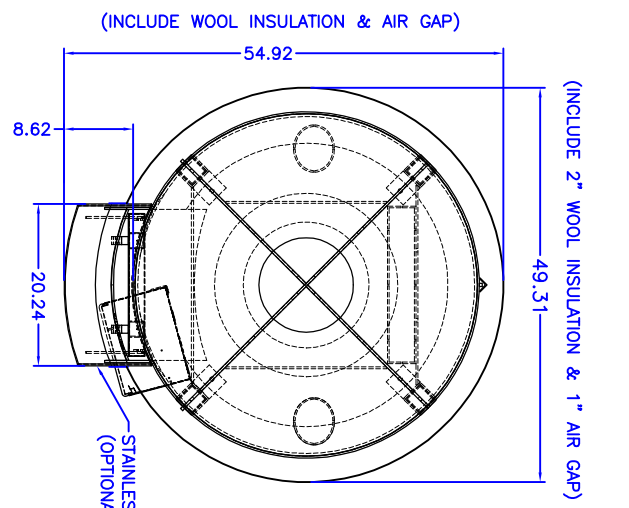

NOTE:

DISPLAY BURNER = 57,000 BTU'S
 TORCH BURNER = 57,000 BTU'S.
 NATURAL GAS.
 GAS SYSTEM 3/4" GAS FITTING.
 ELECTRICAL CONNECTION TO 110V-5A MAINS POWER.
 STANDARD VENTING APPLIES AS PER LOCAL
 AUTHORITY REQUIREMENTS.

THE OVEN IS DELIVERED IN ONE (1) SECTION
 ALSO AVAILABLE IN TWO (2) PIECES:
 UPPER SECTION - APPROX. 1584LBS.
 BASE SECTION - APPROX. 662LBS.
 TOTAL WEIGHT = APPROX. 2262LBS.

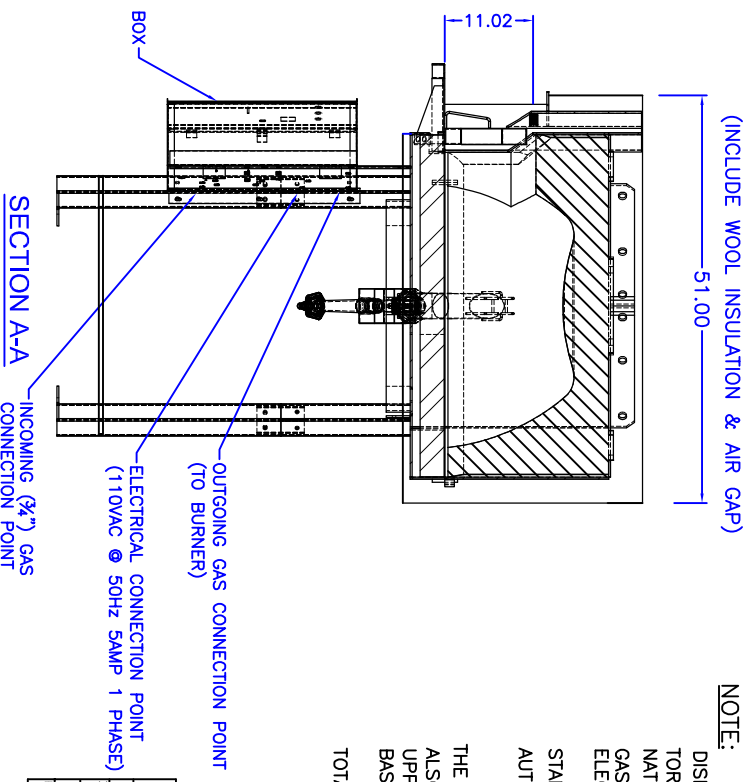
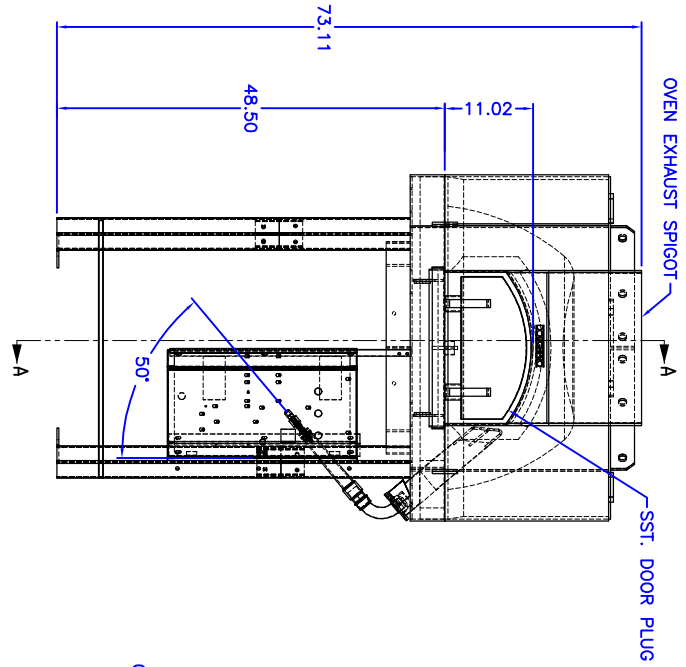

| | | | |
|------------------------------|------------|--------------|--|
| DRAWING AND ENGINEER TO DATE | | DATE | |
| LARGEST DIMENSION SECTION | | 7-28-08 | |
| NAME | | DATE | |
| BRNAN T. SPOUDOM | | | |
| CHECKED | | | |
| ENGINEER | | | |
| TITLE: | | REV | |
| 4 FT. GB. STD. OVEN | | C | |
| SIZE | DWG. NO. | REV | |
| C | 1101234000 | N/C | |
| SCALE: 1/2" = 1'-0" | SHEET 5 | SHEET 1 OF 1 | |