

Mobile Compressor Cart

The DP1500C is a mobile cabinet with a truly heavy-duty whisper silent compressor. It has been specifically selected to power our DP1300 air driven dough press. This heavy duty compressor will eliminate the noise associated with standard compressors.

Features include:

- Stainless Steel construction
- Edged top portion
- Heavy duty whisper silent compressor
- Heavy duty casters
- Designed to fit model DP1300
- Open design for easy access to compressor

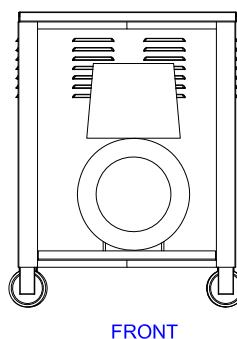
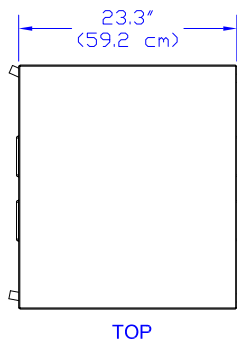
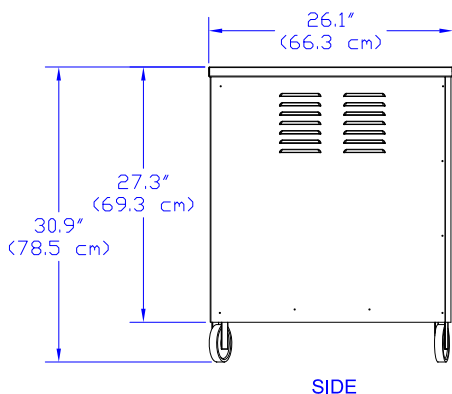

IMPORTANT INFORMATION CONCERNING PROPER INSTALLATION OF AIR COMPRESSOR
Failure to confirm as specified below could nullify manufacturer's compressor warranty!

Minimum gauge wire requirements for power supply lines (including extension cords) when equipment is installed at the following specified distances from electrical service panel:

	25ft.	50ft.	100ft.	200ft.
Min. Gauge wire:	16	12	10	8

For distances greater than 200ft. consult factory before attempting to run. **NOTE:** Compressors require a 120v/60hz/1PH/20amp dedicated circuit.

IMPORTANT NOTICE Refer to and follow compressor manufacturer's operating instruction manual (packed with compressor) **BEFORE attempting** to plug in and operate unit.

Includes 96"L cord and NEMA approved 5-20 plug.

Specifications, Details and Prices are subject to change without prior notice. Please call for current pricing.

DOUGHPRO

20281 Harvill Ave, Perris, CA 92570

(951) 657-0379 (800) 624-6717 Fax (951) 657-4594



Electrical Data: 120v/60hz/1.2hp/15amps
Shipping Weight: 215 lbs. / 98 kgs.

DOUGHPRO®
STEARNS PRODUCT DEVELOPMENT CORPORATION

Website: www.doughpro.com E-Mail: info@doughpro.com