



DOUGHPRO OVEN MODEL: DPO RECT. (52" x 48") ("Full Gas, Gas backup or Solid Fuel only")

The 52 x 48. Series has up to a 31" wide door to give access to the 44"W x 34"D" cooking surface giving an effective cooking surface of 10.4ft². The patented post cast dome construction gives it unique structural and versatility features such as 4 yr guarantee, able to fit through a standard 32" doorway, lifting hooks for easy installation and the ability to "cast in" unique accessories as listed below. The oven is manufactured from high grade castable ceramic material enclosed completely in a housing of 1/4" mild steel. The oven is covered with 2" thick density ceramic wool for the ultimate in heat retention.

All Doughpro ovens are listed with UL and have EPH/NSF4 classification. The gas system meets AGA/CSA requirements. From a cooking perspective, the oven will operate superbly whether fired by gas, wood, coal or combination of gas and solid fuel.

The spectacular performance of the Doughpro Ovens is a result of the huge thermal mass of the ovens unique ceramic convex domed ceiling. The weight of the oven dome oven is typically twice the weight of all other precast ovens on the market. The convex ceiling is typically 16" above the floor giving it the most powerful cooking potential and never seen before thermal efficiencies.

The cooking surface of the oven uses high quality 20lb 3" thick alumina bricks, renowned for their excellent cooking attributes and incredible wear resistance. The use of bricks avoids the unsightly cracking associated with one piece floors. These bricks sit upon a 1" thick VF insulating board and a further 1/4" reinforced steel base.

The oven can be installed to within 1" of non-combustible material, check for local building and fire codes. The oven exhausts through an "eye brow canopy/spigot" above the mouth. The oven must be vented in accordance with local and/or national codes. For more information refer to our web site. www.doughpro.com
The oven comes standard in two parts or optionally can be supplied fully clad in sheet metal and stainless steel to the front facade.

The "DPO 52x48" comes in two(2) sections.

- (1.) Oven body 2310lbs..
- (2.) Base Section. 1190lbs.

The lower leg sections are removable which makes it possible for simple installation into most kitchens where std. door access (32") is available.

Each section will fit into most multi-story building elevators.

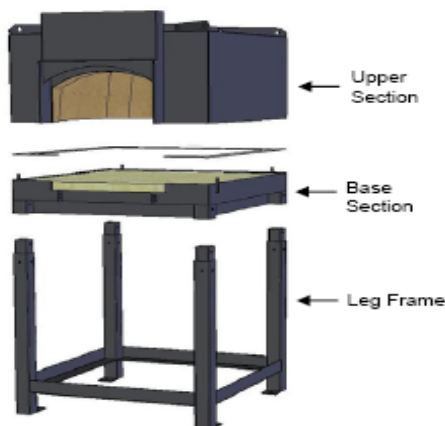

UNIQUE FEATURES:-

- Custom features: Windows, Radiant Flames (thermostatically controlled) & spotlights
- Stainless steel plug doors for all oven mouths.
- Any gas type - Specify at order time.

OPTIONAL OVEN ACCESSORIES / SERVICES

- INSTALLATION
- GLASS DOOR
- DIGITAL THERMOMETER
- INTERNAL SPOT LIGHTS
- PIZZA TOOLS
- DOUGH PRESSES
- COMMISSIONING
- DESIGN ARTWORK
- VIEWING WINDOW
- GRANITE OR STAINLESS MANTLE
- MOUTH EXTENSIONS TO FACILITATE EASIER FACADE CONSTRUCTION

SERVICES REQUIRED:-
FULL GAS—67,000-76,000 BTU.
3/4" Gas Connection.
Nat.& Propane versions available.
Electrical: 110-120V 5amp.
Connection to approved flue/ ducting. (NFPA-96)

APPROXIMATE PIZZA CAPACITY PER HOUR:- @700°F will cook

Size	18"	16"	12"	10"	8"
Pizza Per Hour	25	55	85	134	152

8 7 6 5 4 3 2 1

(INCLUDE 2" WOOL INSULATION & 1" AIR GAP)

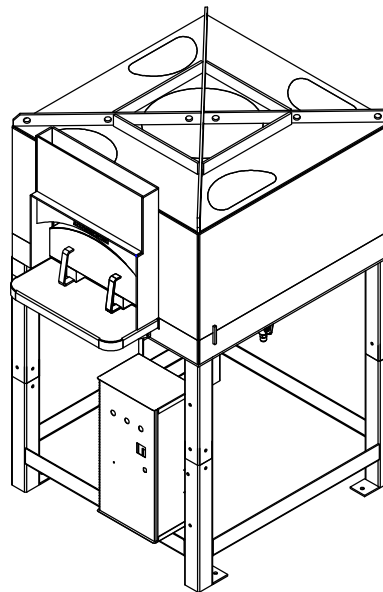
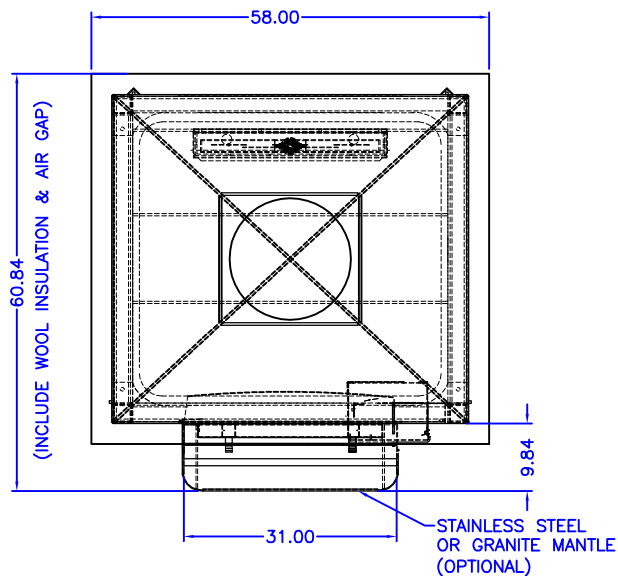

OVEN EXHAUST SPIGOT

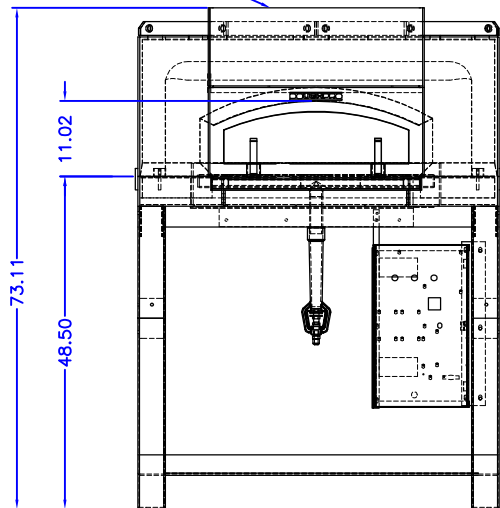

56.16
(INCLUDE WOOL INSULATION & AIR GAP)

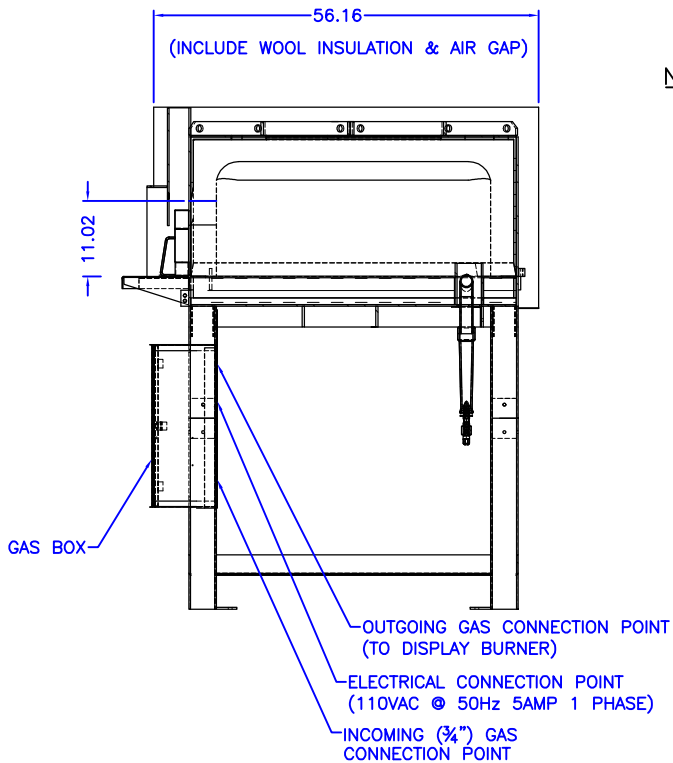

NOTE:

DISPLAY BURNER = 67,000 BTU'S
NATURAL GAS.
GAS SYSTEM 3/4" GAS FITTING.
ELECTRICAL CONNECTION TO 110V-5A MAINS POWER.

STANDARD VENTING APPLIES AS PER LOCAL
AUTHORITY REQUIREMENTS.

THE OVEN IS DELIVERED IN ONE (1) SECTION
ALSO AVAILABLE IN TWO (2) PIECES:
UPPER SECTION - APPROX. 2310LBS.
BASE SECTION - APPROX. 1190LBS.

TOTAL WEIGHT = APPROX. 3500LBS.

DRAWINGS ARE GENERATED BY ENG. DO NOT UPDATE OR SCALE UNLESS OTHERWISE SPECIFIED.		DOUGHPRO		28281 Holly Hill Ave Norris, LA 70570 Tel: (936)657-4579 Fax: (936)657-4579
NAME	DATE	TITLE:		
DRAWN T. SRIJODOM	7-28-08	52 X 48 REC. STD. OVEN		
CHECKED		SIZE C	DWG. NO. 5248072808	REV N/C
ENGINEER		SCALE: 1/4" = 5"		SHEET 1 OF 1

8 7 6 5 4 3 2 1