

# TORTILLAPRO™

Model No.

# DP2000

## Dual Heated Platens!

*Now you can flatten tortilla & pizza dough like a pro with one easy motion!*

Whether you need to simply par bake your dough, or speed up the flattening operation, the Model DP2000 does it all. Tortillas, mushi skins, pizza and especially thin crust pizzas can all be flattened faster than any other method used today.

Each platen contains an independent heating system with separate controls that provide a temperature range of 0° - 425°F. This allows you to dial in exactly the right temperature for each side of the product from a thick crust pizza to a paper thin mushi skin.

Produce up to 4 tortillas in a few seconds or around 1000 per hour.

Manually operated, no motor or compressors required.

Flattens all tortilla and pizza dough up to and including 18" (46 cm) diameter.

Heat potential for upper & lower platens help cold tortilla and pizza dough flow faster.

Perfect production system for just about any volume of tortillas & pizza dough.

Compact size fits just about anywhere.

Thickness adjustment control dial.

Safe to operate and clean.

 Listed.



**Produce Up To 1000 Tortilla per Hour**

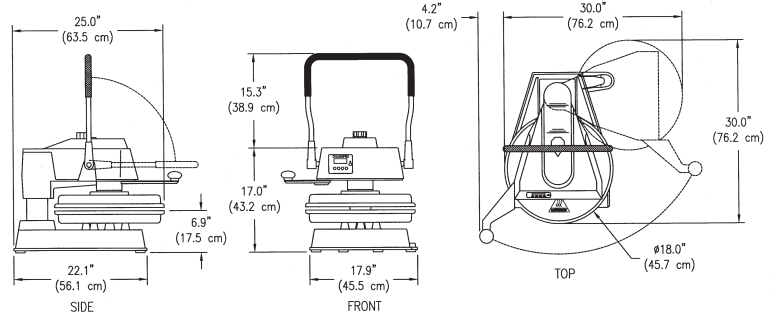

ON/OFF Switch	Yes	Electrical Data 240v/50-60hz 2800w/11.66amps
Automatic Timer	No	
Adjustable Thickness	Yes	
Temperature Control	Dual	Shipping Weights 200 lbs. / 82 kgs.
Maximum Heat	0-450°F	

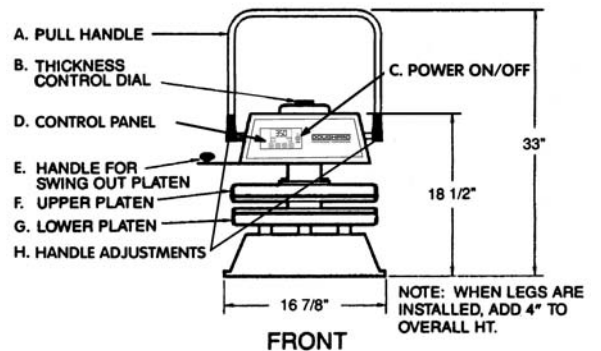

Includes 72" NEMA 6-15P approved cord and plug.

**The DP2000 can press up to 4 tortilla balls at one time.**

*Specifications, Details and Prices are subject to change without prior notice. Please call for current pricing.*

DOUGHPRO

20281 Harvill Ave, Perris, CA 92570

(951) 657-0379 (800) 624-6717 Fax (951) 657-4594



# DOUGHPRO®

STEARNS PRODUCT DEVELOPMENT CORPORATION

Website: [www.doughpro.com](http://www.doughpro.com) E-Mail: [info@doughpro.com](mailto:info@doughpro.com)