

## The A4 Paper Test

Without access to suitable measuring equipment, the most effective method to correctly calibrate the oven exhaust is using the A4 Paper Test as explained below.

The A4 paper test has been developed to be a simple and effective gauge to determine the draw (suction) at the oven exhaust spigot (top of the oven mouth). This is a common and often overlooked cause of poor oven performance.

Too much suction causes the oven to lose heat & use excessive fuel. Too little suction allows smoke and combustion gas to escape into the kitchen. There is a fine balance between too much and too little. To adjust the draw, you will need to access the System Damper adjuster installed in the Flue transition or ductwork connected to the oven spigot. For systems that are directly connected, Doughpro recommends use of a fan with adjustable settings.

Too much draw (suction)

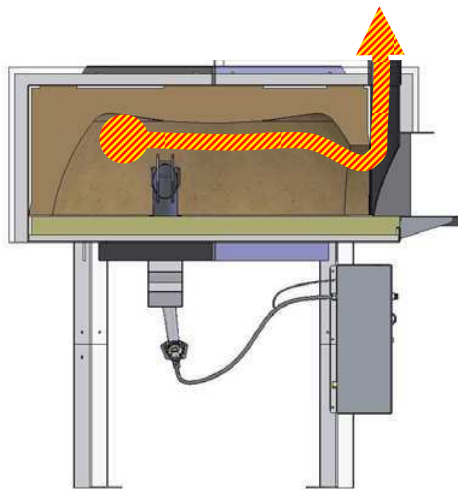

Not enough draw (suction)

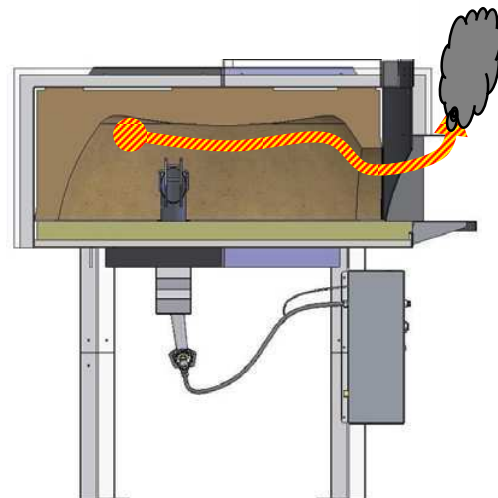

For all other systems, it is advisable to check the exhaust spigot temperature when the oven is fully heated and operational. Adjust the damper to obtain 266°F -302°F.

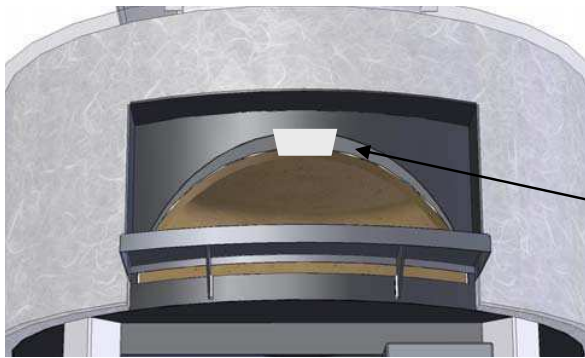

Exhaust spigot with paper folded width wise held in position.  
(4.5 ft Round oven)

With the exhaust fan running, the suction at the exhaust spigot at the mouth of the oven should be enough to hold a sheet of A4 paper folded in half width wise. However, the suction should NOT be so much that it will hold the A4 paper when folded lengthwise.

NOTE: It is acceptable to use either A4 or Letter size paper.

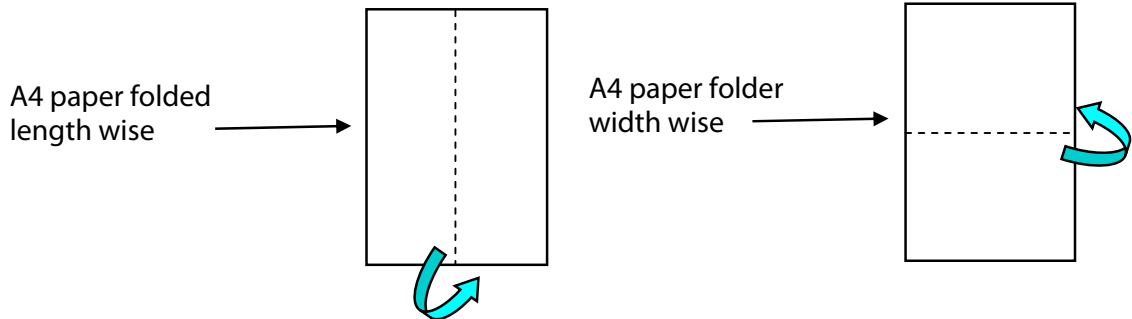

If the sheet falls from position the System Damper will need to be adjusted (opened slightly) to increase the airflow.

To adjust, loosen wing nut and move the quadrant adjuster until correct required air flow is achieved.

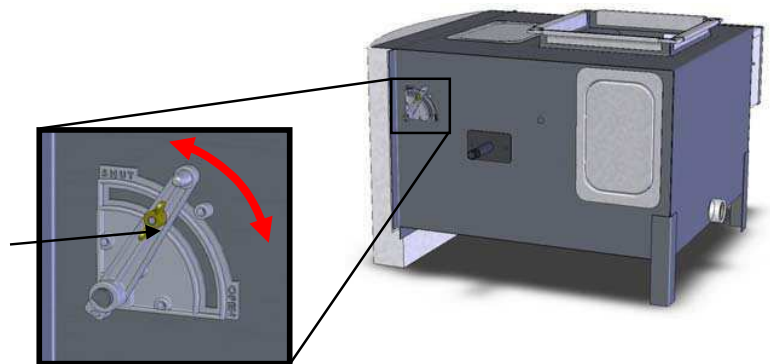

NOTE: When the System Damper is in a "SHUT" position, a small amount of air can still pass through the damper.

With the A4 sheet folded length wise the suction should not be able to hold the paper in position at the flue spigot at the mouth of the oven. If the sheet stays in position the System damper will need to be adjusted (closed slightly) to decrease the airflow.

In the case of multi door ovens or ovens fitted with a char grill, repeat these instructions for all doors. (For ovens fitted with a Char Grill, suction is automatically biased to the Char Grill side of the exhaust spigot)

Careful work here will increase performance and help to resolve problems otherwise overlooked. Remember, too much suction removes great amounts of heat from this style of oven. Correct calibration is critical.

This test is simple and approximate. Additional calibration may be required should spillage be observed or if the exhaust spigot temperature exceeds the recommended 266-302°F (max).

If you have any questions, contact Doughpro's Technical Support.  
[support@doughpro.com](mailto:support@doughpro.com)

## Ventilation Test

As mentioned in the earlier section Venting the Oven, for all ovens with gas, an open vent must always be made available to the underside of the oven. To sustain a flame, the oven utilizes primary and secondary air (oxygen) from below the oven floor.

When firing the oven with gas, if the flame burns erratically check that the flame is not being drawn under the oven and leaking from the blow-back chute.

If flames are visible here, this means there is an ambient pressure imbalance. (Higher pressure in the oven – Lower pressure below the oven)

Blow-back chute

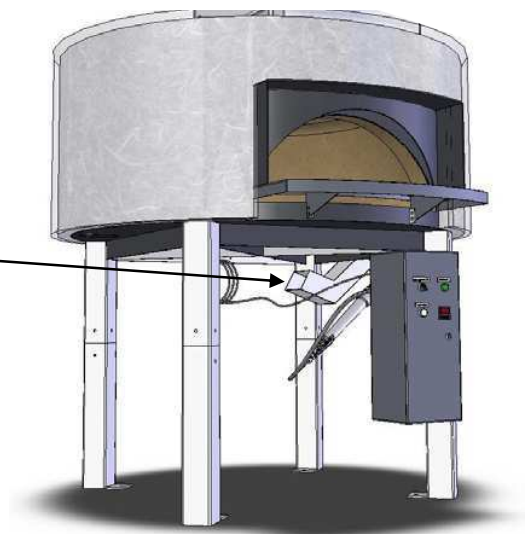

If smoke or flames are visible during the Ventilation test, shut the system immediately and refer to the section System Balancing.

## System Balancing

Having checked that the oven is correctly vented and that the Flue is correctly calibrated, in some cases there may be external air pressure differences that can affect the performance of the oven.

In some instances an imbalance may occur between the space above the oven and the space below the oven. This may result in air being drawn from within the oven to compensate for this imbalance.

A direct result of this may be that the flame, or smoke, is being drawn under the oven causing the flame to behave erratically and the ovens performance deteriorates.

In most cases this is due to two (2) possible causes:

- Insufficient ventilation below the oven

In the case of insufficient ventilation below the oven, refer to Venting the Oven in this manual.

- Excessive draw from above the oven

If there is excessive draw from above the oven, this may result in the ventilation below the oven being insufficient.

Alternatively, to resolve this problem, increase the size of the ventilation inlets below the oven.

For further assistance refer to the technical assistance section on [www.doughpro.com](http://www.doughpro.com) or contact Doughpro's Technical support. [support@doughpro.com](mailto:support@doughpro.com)